

A520 PREMIER DUAL
MASSAGE CHAIR
OPERATION INSTRUCTIONS

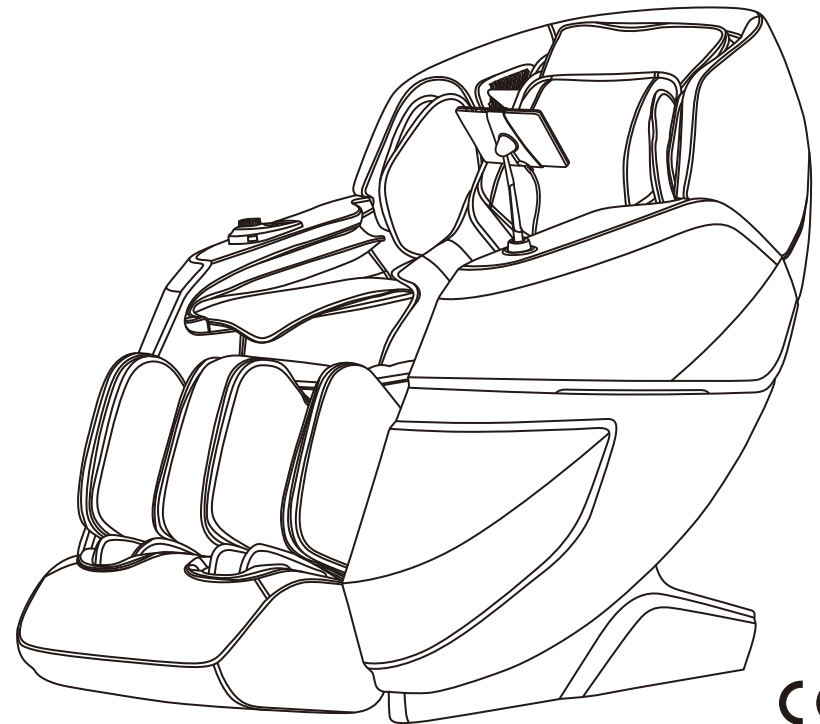

SAVE THESE INSTRUCTIONS



CE



Thanks for purchasing this product. Please read this manual instruction carefully in order to know how to use this product correctly before operation. Please pay more attention to some important safety warning and keep this manual book properly for future use.

Note: Our company reserves the right to change and explain the design of the product. If there is some difference between the product function in market circulation and the description in the manual, it is a normal update of the product, and our company will not inform you otherwise. The specific product function and color shall prevail in kind.

CONTENTS

Before use

Safety precautions	02-04
Installation parts	05
Place massage chair	06-07
Before use	08-09
Product structure	10-14

Usage method

Operation Instructions	15-26
Massage close	26

Maintain



Cleaning and Maintenance	27
--------------------------	----

Important

Troubleshooting	28
Product Specifications	29

Safety Precautions (must be observed)

- Please read all relevant instructions carefully before use.
- The notes marked here will help you to use the product safely and correctly.
- In order to clearly indicate the extent of harm and damage, precautions are divided into **"Warning"** and **"Caution"** that may be caused by incorrect use. Both of them are important for safety and must be followed.

 Warning	Indicates that serious injury or death may result from improper use.
 Caution	Indicates that misuse may cause minor injury or property damage.

- Please pay attention to the symbol before each safety item.

 Forbidden	Absolute prohibition
--	----------------------

The following populations should not use this product

 Forbidden	<ul style="list-style-type: none"> ■ The device is not intended for use by persons (including children) with physical disabilities, sensory or neurological impairments or who lack experience and common sense, unless they are supervised and instructed in the use of the device by those responsible for their safety. Children must be supervised to ensure they do not play with instruments. ■ Patients with osteoporosis. ■ Patients with heart disease or wearing electronic medical devices such as a pacemaker. ■ People who have a fever. ■ Pregnant women or women on their menstrual period. ■ Patients who are injured or have a skin disease. ■ When unsupervised, any children are under the age of 14 and those unconscious are not allowed to use this product. ■ People who are told by their physicians to have rest or who feel unwell. ■ People whose bodies are wet are forbidden to use this product. ■ This product has a hot surface. Persons insensitive to heat must pay attention when using this product. ■ If the supply cord is damaged, to avoid danger, it must be replaced by a professional from the manufacturer, its maintenance department or similar department
--	---

Safety Precautions (must be observed)

Important safety warnings	
 Warnings	<ul style="list-style-type: none"> ■ Do not allow children to touch any movable part of this product. ■ Use the well-grounded power supply unit suitable for this product. ■ Pull out the plug after use or before cleaning to avoid any physical injury or damage to the product. ■ Operate this product as instructed in this manual. ■ Do not use any parts or accessories which are not recommended. ■ Do not use this product outdoors. ■ Please read the Operation Instructions carefully before operation. ■ Never use this product for any other purpose not listed herein. ■ 20 minutes of usage each time is recommended. ■ Do not use this product if the cover or leather is broken or damaged. ■ Do not drop anything into this product. ■ Never fall asleep while using this product. ■ Do not use this product if you are drunk or feel unwell. ■ Do not use this product within one hour after a meal. ■ Do not use this product with excessive force to avoid any injury.

Safety precautions	
 Caution	<ul style="list-style-type: none"> ■ Check whether voltage is consistent with the specification of this product. ■ Never insert or pull out the plug with a wet hand. ■ Do not let water flow into this product to avoid electric shock or cause damage to this product. ■ Do not pull the power cord when plugging or unplugging it. Rough handling is forbidden. ■ Do not damage the wire or modify the circuit of this product. ■ Do not clean live parts of this product with a wet cloth such as a power switch and plug. ■ Be away from this product in case of power failure to avoid any injury if power is restored suddenly. ■ Stop using this product at once while it works abnormal, and consult your local supplier. ■ Stop using this product if you feel unwell, and consult your health care practitioner .

Storage conditions	
 Caution	<ul style="list-style-type: none"> ■ Storage room temperature: 5 °C to 40 °C. ■ Relative humidity (RH) between 20% and 80%; free of corrosive gases, and a well-ventilated room.

Safety Precautions (must be observed)

Product service and maintenance	
 Caution	<ul style="list-style-type: none"> ■ This product should be maintained by the service center designated by the manufacturer only. No user should disassemble or maintain it without permission. ■ Do not forget to turn off the main power switch after usage. ■ Do not use this product if the power socket becomes loose. ■ If this product will be left unused for a long period of time, it is necessary to roll up the power cord of this product and store this product in a dry and dust-free environment. ■ Do not store this product at a high temperature or near open flame. Avoid prolonged exposure to direct sunshine. ■ Please clean this product with dry cloth. Never use thinner, benzene or alcohol. ■ The mechanical components of this product are specially designed and manufactured, so no special maintenance is needed. ■ Do not use a sharp object to stab at this product. ■ Do not roll or pull this product on any uneven ground. Instead, it should be lifted before moving. ■ Please use this product intermittently. Do not keep it working continuously for a long period of time.

Operating environment	
 Caution	<ul style="list-style-type: none"> ■ Do not use this product in a very moist environment such as the bathroom. ■ Stop using this product immediately when the ambient temperature changes sharply. ■ Do not use this product in any heavily-dusty or caustic environment. ■ Do not use this product in a small space or a place without good ventilation.

Solutions to ordinary malfunctions	
 Caution	<ul style="list-style-type: none"> ■ If the motor sounds during operation of this product, this is the normal operation sound. ■ If the controller cannot work normally, check whether the plug and the power socket are connected reliably, and whether the power switch is turned on. ■ If the rated working time is over, this product will automatically activate the power-off button; If this product keeps operating for a long period of time, the temperature protector will stop this product automatically. The product can be used again after half an hour.

Installation parts

Calf installation instruction

1. Insert the harnesses and air hose of the footrest into the front socket of the frame assembly respectively (Figure 1).
2. After the harnesses connection is completed, open the footrest fixing covers on both sides of the frame assembly (Figure 2).
3. Lift the footrest, put it into the slot then flip the fixing cover, and finally fix it with 2 M4 screws (Figure 3)

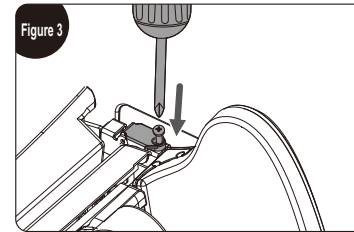
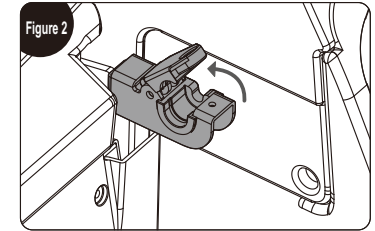
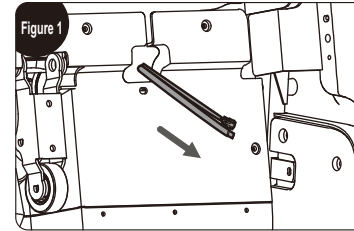

Remote control holder installation instruction

Align the threads on the bracket assembly support knob with the corresponding thread position of the bracket mount on the armrest, turn clockwise and tighten to secure. (Figure 1)

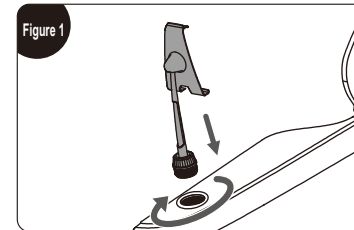

Place massage chair

Installation placement

Make sure there is enough space for the massage chair can be tilted at least 10 mm.



Do not expose the massage chair directly to high temperature environment due to sunlight (such as: in front of heating equipment), and place it to where can avoid high temperature and direct sunlight. It is recommended to lay a soft cushion for long-term use in a designated location. When laying the cushion, the size of the cushion should be enough to cover Keep the range where the machine touches the floor and the range where your feet touch the floor.

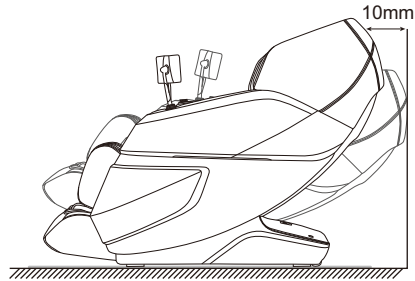

Product lift instruction

Require team work to lift and move the chair to avoid injury.



1. Please lift the massage chair to move it on vulnerable ground such as wooden floor.
2. When moving on a similar wooden floor, it is recommended to lift it. Avoid damage to the casters. When the floor is lifted and moved to the designated position, be careful to keep your hands out of the way to avoid injury, and be careful of your feet being crushed. Do not let go of the unit until the unit is completely flat, the floor may be damaged, therefore, it is recommended to place mats, etc. on the floor.

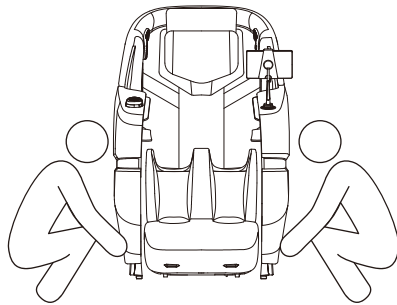

Place massage chair

Move method

Use the rear casters to move the massage chair. Move the chair by tilting it down and backward about 45° as shown in the diagram.



NOTE: Excessive force to title will cause the chair to tip over completely and product damage.

1. Before moving, please shut down the machine properly to reset the whole machine, and then cut off the power.
2. Please keep the chair vacant when moving. (People, pets or clutter will not be able to stay on the chair.)
3. When moving, do not cross a drop barrier higher than 2mm or a gap greater than 5mm.
4. When using casters to move this product, single continuous movement is not supported; if the distance exceeds 50 meters, please make this product move slowly and evenly.

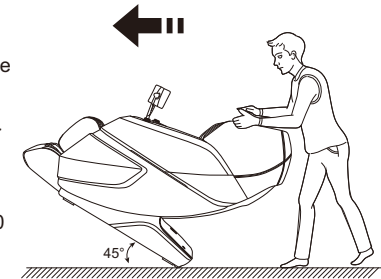

How to disassemble and use headrest cushion and backrest cushion

Using a headrest cushion can reduce the intensity of kneading massage on the neck and shoulders, and you can decide whether to use a headrest cushion according to your needs (recommended to use a headrest cushion). The backrest cushion and the backrest are connected by a zipper (1), and the headrest cushion and the backrest cushion are connected by a zipper (2).

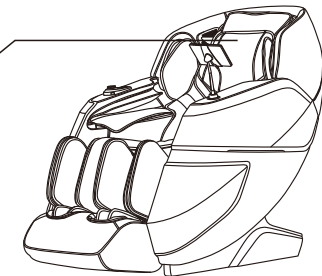
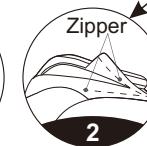

Before use

Check around

Make sure that there are no people, pets and other objects around the unit.

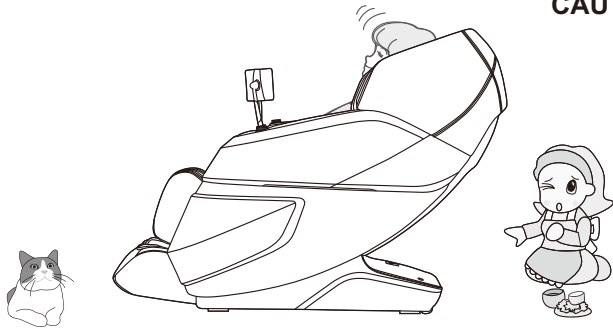

Make sure there are no foreign objects in the gaps of the machine

Before massaging, make sure that no foreign objects are caught in the legs, feet, etc.

Under no circumstances allow hands, feet, and head to penetrate into the area between the lower leg mechanism and main body, or the area between the armrest and the capsule.

Under no circumstances should hands, feet, or head sink under the fabric or leather covering of the massage area.

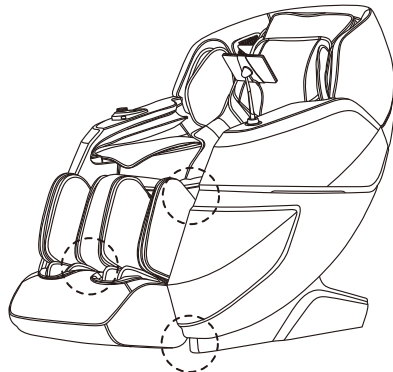

Before use

Turn on the power

CAUTION

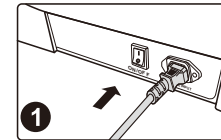

1 Plug in power cord

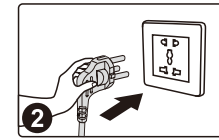

2 Schematic diagram of power on

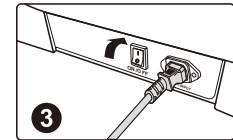

3 Turn on the power switch ("I" position)



Warn

- Please check the power cord and plug for damage before use.
- Please supply power to this product in accordance with the working power requirements of this product's calibration.
- It is strictly forbidden to use a power supply other than the nominal power supply of this product.
- It is strictly forbidden to connect various power conversion devices without authorization to supply power to this product.

Product structure

Description of Components

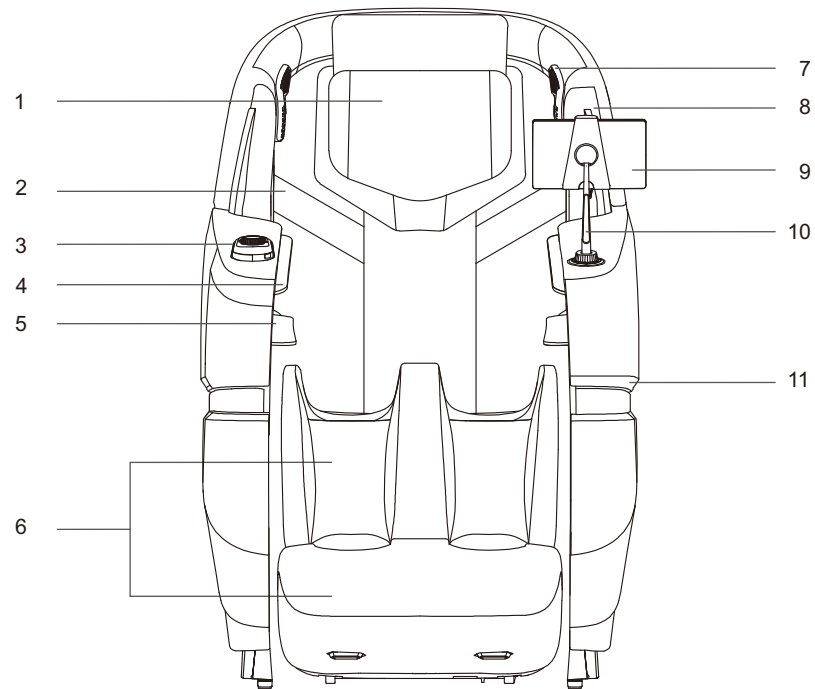

- 1. Head cushion
- 2. Back cushion
- 3. Armrest shortcut keys
- 4. Arm air pressure
- 5. Health sensor
- 6. Leg massage unit

- 7. Speaker cover
- 8. Shoulder air pressure
- 9. Remote control
- 10. Remote control holder
- 11. LED light

Product structure

Schematic view of functional distribution

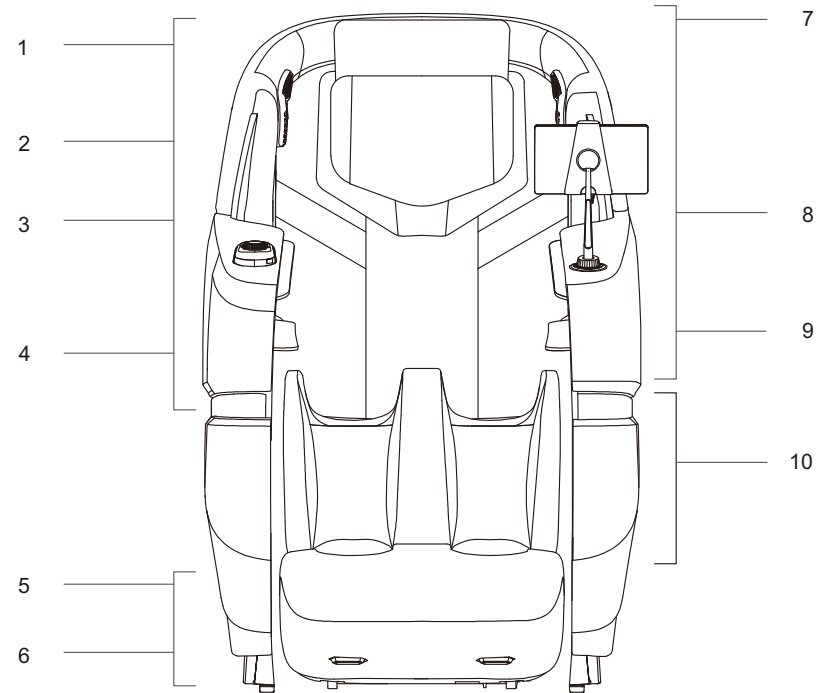

- 1. Right side of the head
Voice control function

- 2. Shoulder
Air Bag massage

- 3. Arm
USB charging port
Air Bag massage

- 4. Plam
Air Bag massage

- 5. Leg
Air Bag massage

- 6. Sole
Roller massage
Air Bag massage

- 7. Both sides of the head
3D digital audio
Music player

- 8. Head and neck to bottom
Dual Massage mechnaism

- 9. Waist Heating

- 10. Leg
Air Bag massage

Product structure

I.Remote controller keys instruction

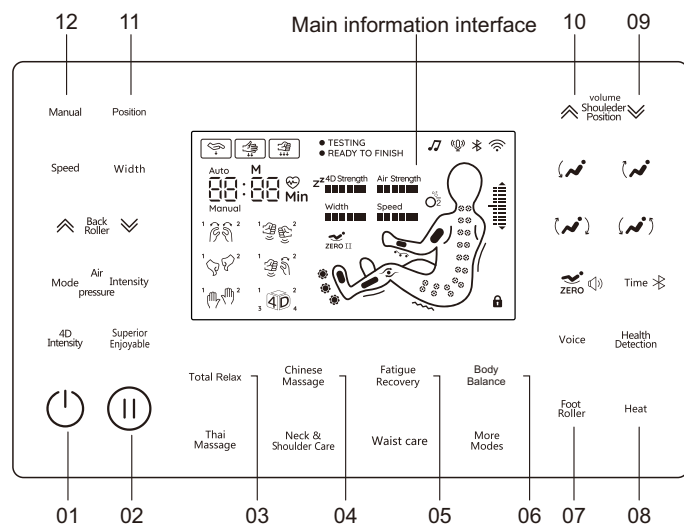

- 01.Power key: Turn on/off the massage chair
- 02.Pause key: Pause/start the massage function
- 03.Total relax mode: Start Total relax mode
- 04.Chinese massage mode: Start Chinese massage mode
- 05.Fatigue recovery mode: Start Fatigue recovery mode
- 06.Body Balance mode: Start Body Balance mode
- 07.Foot roller key: Turn on/off roller, Roller intensity with 3 levels
- 08.Heat key: Turn on/off heating function
- 09.Down key: Adjust shoulder position down or Long press to adjust volume down
- 10.Up key: Adjust shoulder position up or Long press to adjust volume up
- 11.Mode key: Choose different massage area
- 12.Manual key: Start manual mode, 11 kinds of manual mode can be chosen. Long press this key to control 2 massage hand

Product structure

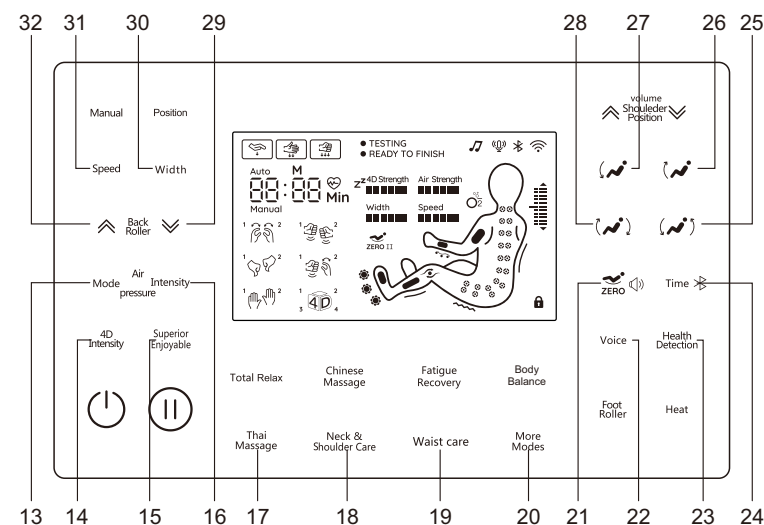

- 13.Air pressure key: Choose different air pressure mode
- 14.4D intensity key: Adjust 4D intensity
- 15.Superior enjoyable Key: Start Superior enjoyable mode
- 16.Air intensity key: Adjust air intensity
- 17.Thai massage key: Start Thai massage mode
- 18.Neck & Shoulder Care key: Start Neck & Shoulder Care mode
- 19.Spine Traction key: Start Spine Traction mode
- 20.More mode key: Cycle through more automatic modes
- 21.Zero key/Broadcast key: Short press to adjust zero gravity while long press to turn on/off broadcast
- 22.Voice: Press and hold to turn on or off the voice function, and short press to wake up.
- 23.Health check key: turn on or turn off health check function.
- 24.Time key/Bluetooth: Short press to timing, long press to turn on/off Bluetooth
- 25.Seat-up: Adjust the massage chair angle upwards.
- 26.Calf-up: adjust the calf frame up.
- 27.Calf-down: adjust the calf frame down.
- 28.Seat-down: Adjust the massage chair angle downwards.
- 29.Down key: Adjust massage hand down.
- 30.Width key: enter into save interface.
- 31.Speed key: Adjust massage speed with 5 levels
- 32.Up key: Adjust massage hand up

Product structure

2. Description of armrest shortcut keys

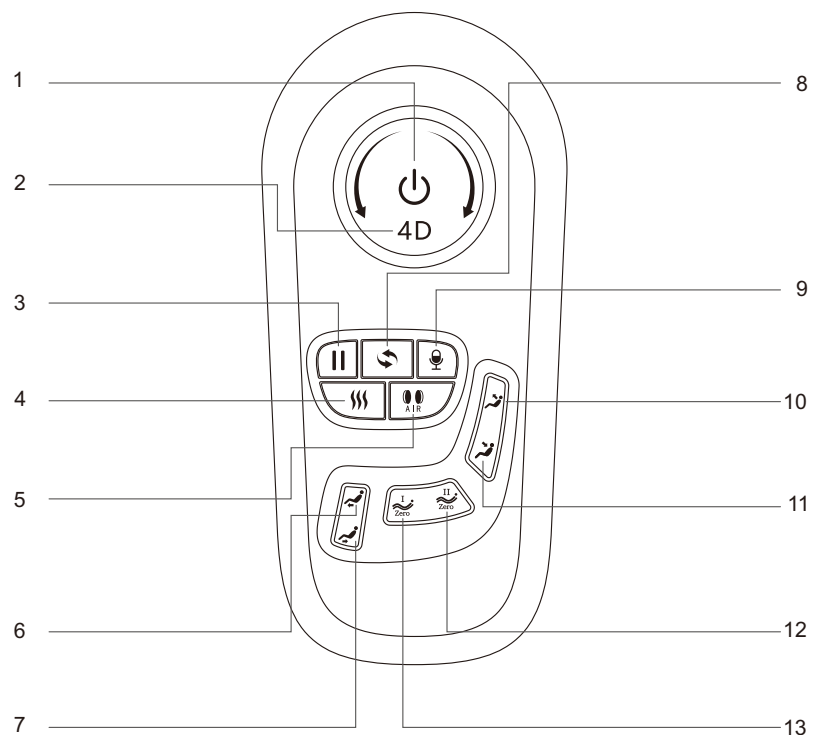

1. Power key: Turn the massage chair on or off.
2. 4D intensity key: Adjust massage intensity (Decrease to the left, increase to the right)
3. Pause key: Pause massage or exit from pause massage
4. Heating key: on/o ffbback heating.
5. Air pressure key: on/o ffair pressure massage function.
6. Calf-up: adjust the footrest upwards.
7. Calf-down: adjust the footrest downwards.
8. Auto mode key: Select Auto mode(all auto mode circulate in order).
9. Voice control key: Press and hold to turn on or o ffthe voice function, and short press to wake up.
10. Back part lifting: adjust the lifting of backrest
11. Back part reclining: adjust the reclining of backrest
12. Zero gravity2: Adjust the chair angle to zero gravity2.
13. Zero gravity1: Adjust the chair angle to zero gravity1.

Operation Instructions

II. Start massage

1. Press the power key (⏻) on remote controller or ⏻ on armrest to start the massage, the default is Auto mode 1.

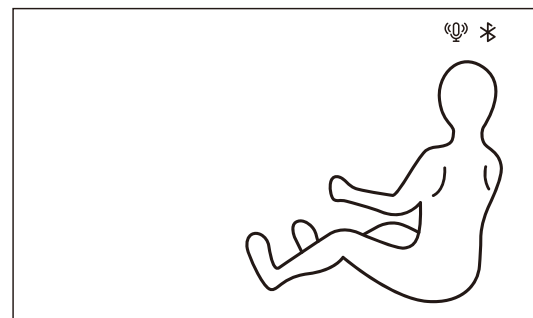

2. The massage chair will adjust the angle to zero gravity automatically after starting the massage. (Zero gravity angle suitable for massage) After zero gravity, the massage will start body scanning, Please keep your body and sitting posture close to the massage chair.
3. Body scanning. Start body scanning after adjusting the angle, Users need to lie back against the massage chair and wait for the body scanning to complete.
4. After body scanning, Remote control or broadcast will prompt user to adjust shoulder position. If massage hand suit for your shoulder position, no need to adjust shoulder position, While massage hand not suit for shoulder position, please use shoulder Up key (⤴) or Down key (⤵) to adjust. After 20 seconds, start massage. The default will use current massage hand position if no operation over 20 seconds. Noted: Repeated selection of the same auto can be skipped directly into the massage

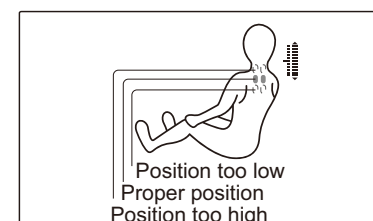
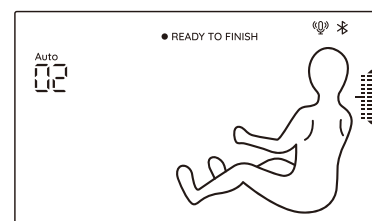

III. Automatic program (please use this function after the chair is turned on)

1. Automatic program selection
(1). Click on the automatic program button area on the remote control, then select the automatic program to start massage.

Operation Instructions

(2). There are 18 automatic programs to be chosen in automatic program button area. Including: Total Relax, Chinese Massage, Relieve Muscle, Body Balance, Thai Massage, Neck & Shoulder Care, Spine Traction more modes (including Superior Enjoyable, Full-body Stretch, Leg&foot Relieve, President Cosy, Keep Fit, Office Regimen, Health Recharge, Energy Boost, Lunch Break, Back Spa, Sweet Dream.



Schematic diagram of automatic massage program selection

2. Automatic program introduction

Function	Description	Display
Total Relax	Apply deep pressure on the neck, back and waist, buttocks, and legs by means of kneading, patting, finger pressing techniques mainly to relieve the fatigue on body, allowing the body to better relax.	01
Chinese Massage	By means of Traditional Chinese medicine massage technique mainly, apply 3D massage on the back and waist so as to promote the blood circulation of the back and waist, soothe the meridians and relieve the blockage of the back and waist through massage. It is suitable for people with back and waist pain, and lumbar muscle strain. Massage intensity is gentle.	02
Relieve Muscle	Apply deep pressure on the neck, back and waist, buttocks, and legs by means of kneading, patting, finger pressing techniques mainly to relieve the fatigue on body, allowing the body to better relax.	03
Body Balance	Apply full air massage mainly, with the use of airbags for cross circulation of kneading and pressure, so as to promote blood circulation, alleviate pain in various body parts, and deeply relieve muscle fatigue. (Remarks: full air massage mainly, with frequent air massage action)	04
Thai Massage	Mainly use calf and backrest electric push rod to clamp legs, hands and shoulders with the aid of air massage, and then apply stretching massage, while the movement holds against the back and waist for 3D medical massage, so that the body is in the Thai stretching state. It is suitable for people under high stress to improve their head-down on chest and humpback. Massage intensity is strong.	05

Operation Instructions

Neck & Shoulder Care	Massage the neck and shoulders by means of kneading and stretching techniques mainly, and also the upper back by medical massage, and then press the Jianjing acupoint to relieve cervical spondylosis and achieve the effect of relaxing the muscles of the neck and shoulders. Massage intensity is gentle, suitable for people working in office and suffering from cervical fatigue.	06
Spine Traction	Massage the waist by means of kneading, patting and medical massage mainly, while the movement holds against the back and waist for 3D medical massage, so as to relieve lumbar spine pain; combined with the thermostatic heat configuration around the waist, maintain a comfortable temperature to bring warm massage experience; with gentle and moderate massage intensity and comfortable temperature, bring warm massage experience.	07

More modes		
Function	Description	Display
Superior Enjoyable	Apply air massage on the whole body, with the foot roller and calf kneading massage. Calf stretching function is canceled, suitable for the elderly and people suffering stress on back. The massage intensity is gentle.	08
Full-body Stretch	By means of kneading, patting, finger pressing and medical massage techniques mainly, clamp the legs, hands and shoulders with the aid of air massage, and then apply stretching massage to soothe the meridians, promote blood circulation, relieve blockages in the body.	09
Leg&foot Relieve	Massage the shoulders and waist by means of kneading, patting, kneading and patting mainly, apply air massage on the legs and feet for squeezing massage, allowing more soothing leg and foot massage, suitable for sedentary people with low stress on the legs and feet, not only relieving the cervical spine, lumbar spine pain of sedentary people, but also soothing the legs and feet. Massage intensity is gentle.	10
President Cosy	Massage the shoulders, neck, back and waist by means of kneading, patting, kneading and patting mainly, to relieve fatigue, promote blood circulation, and release stress by such deep massage. It is suitable for men, and the massage intensity is moderate.	11







Operation Instructions

Keep Fit	Massage the shoulders, neck, waist and hips by means of kneading and finger pressing techniques, through the massage on the whole body, to relax the body and mind, and enjoy the queen-level treatment. It is suitable for women, and the massage intensity is gentle.	12
Office Regimen	Massage the shoulders, neck and waist by means of kneading, patting, kneading and patting techniques mainly, to relieve shoulder and neck pain, improve lumbar muscle soreness and maintain lumbar spine through such deep massage. It is suitable for office white-collar and sedentary people, and the massage intensity is moderate.	13
Health Recharge	Deeply massage the whole body by means of kneading, patting and finger pressing techniques, to promote blood circulation throughout the body and prevent blood clots. It is suitable for people who live at home for a long time and do not like to go out, and the massage intensity is moderately gentle.	14
Energy Boost	Massage the waist, shoulders and neck by means of kneading, patting, kneading and patting techniques, to awaken the body's vital energy, stimulate physical energy through such deep massage of the whole body with the massage intensity being heavy, which is suitable for people with strong stress, such as athletes, for stimulating the potential before a race.	15
Lunch Break	Massage the back and waist by means of kneading and patting techniques, and press the Shenyu acupoint, to improve the quality of lunch break, so that the user is more energetic in afternoon work. It is suitable for office workers, and the massage intensity is gentle.	16
Back Spa	Deeply massage the whole body by pressing related acupoints by means of kneading, patting, finger pressing and other massage techniques, to let the stimulation fully reach the deep layer of muscle tissue, feel warm locally combined with the function of hot compress, and regulate the Qi and blood in a bid to achieve the effect of warmth and damp expelling.	17
Sweet Dream	Massage the shoulders, neck, back and waist by means of kneading and medical massage techniques, and press the acupoints of Fengchi and Shenyu, to improve the sleep quality and help sleep. It is suitable for people suffering from poor sleep, and the massage intensity is gentle.	18

Operation Instructions

V. Manual program (please use this function after the chair is turned on)

1. Massage modes, press the mode key on remote control to select massage modes
 (1) There are 11 massage modes, including Knead, Flap I, Flap II, Knead&Tap, Shiatsu I, Shiatsu II, Grasp, 4D I, 4D II, 4D III and 4D IV. Press the mode selection key to enter the manual mode.
 (2) Massage mode displayed on the LCD interface.

Function	Massage roller adjustment	
Knead 	Speed	Adjustable speed in five levels
Flap I, Flap II 	Speed and width	
Knead&Tap 	Speed	
Shiatsu I, Shiatsu II 	Speed and width	
Grasp 	Speed and width	
4D1, 4D2 	Speed	Adjustable speed in five levels
4D3, 4D4 	Speed and width	

2. Massage speed: users can only adjust the speed after entering manual mode by pressing the speed key.
 (1) There are five speeds from speed 1 to speed 5. Speed 1 is the minimum speed and speed 5 is the maximum. The speed cannot be adjusted when the massage mode is stopped.
 (2) Massage speed displayed on the LCD interface

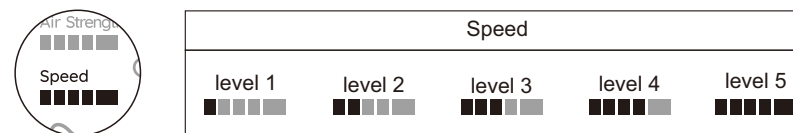



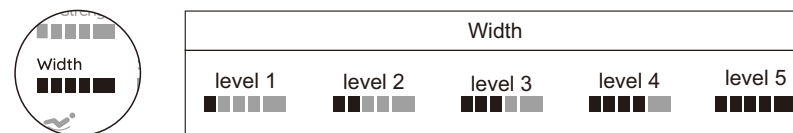

3. Massage width: users can only adjust the width after entering manual mode by pressing the width key.

- (1) There are five massage widths from width 1 to width 5. Width 1 is the minimum width and width 5 the maximum. Please adjust the width in the following massage modes: Stop, Tap I, Tap II, Shiatsu I, Shiatsu II, 4D III and 4D IV.
 (2) Massage width displayed on the LCD interface



Operation Instructions

4. Massage part: pressing the key on remote control to select massage part.
 (1) There are five massage part, including "Fixed point," "Partial," "Upper back," "Lower back" and "Full back." After selection by pressing the mode key to enter manual mode.
 (2) Massage part displayed on the LCD interface

Function	Description
Spot 	Fixed-point massage at fixed-point position.
Partial 	Back and forth massage of small localized area
Upper 	Back and forth massage of upper back
Lower 	Back and forth massage of lower back
Full 	Back and forth massage of full back

You can adjust the massaged area with the Up key and Down key in the information interface when select the Fixed point massage and Partial massage mode.

V. Other Function (please use this function after the chair is turned on)

1. Air mode selection. as shown in the figure below, pressing the mode key to select a Air mode. The Air mode include: Whole Body, Lower Body, Upper Body, Full of the Air massage function.

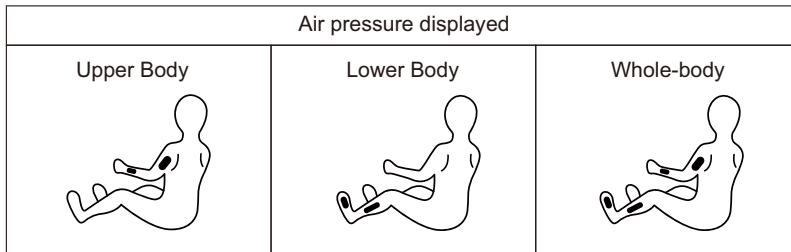

2. Air pressure strength adjustment. After the airbag massage function is turned on, the air pressure can be adjusted from level 1 to level 5. Level 1 is the minimum strength and Level 5 is the maximum.

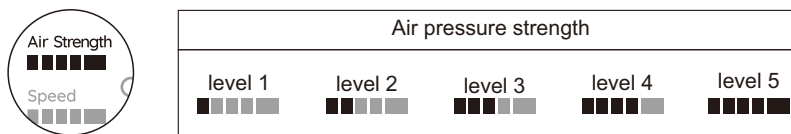

Operation Instructions

3. Heating switch: Press the heating button  on the remote control or armrest to turn the heating function on or off.
 (1) Heating function displayed on the LCD interface

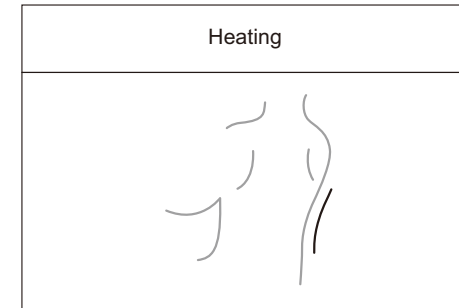

4. Sole roller: press the sole roller key to select roller modes (Fast, Medium, Slow, Off)
 (1) Sole roller displayed on the LCD interface

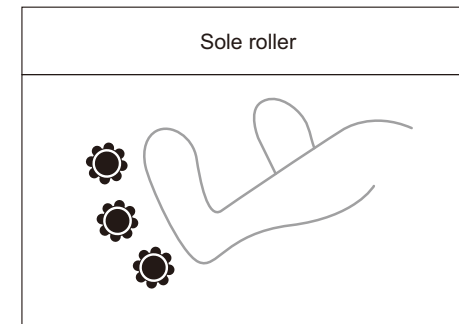

Operation Instructions

5. Bluetooth: Turn on and turn off the Bluetooth speaker function by long pressing the Bluetooth key on remote control. After the Bluetooth speaker function is enabled, you can play music by connecting to a smart device (mobile phone, tablet, etc.).

The connection method is as follows:

- (1) Turn on the Bluetooth function of the smart device, search for the Bluetooth name with the words "IMCM-XXXXXX" and connect.
- (2) Open the music player on the smart device to play music.

6. Voice Prompt: Turn on and turn off the voice prompt function and background music by long pressing the voice prompt key on handle.

- (1) Voice Prompt: During the process of using the massage chair, the user will be prompted how to use the massage chair correctly, helping new users to get familiar with the massage function more quickly.

7. Volume: Long press the Up key and the Down key to adjust the volume. There are 15 volume levels available.

8. Health check: Pressing the health check button on remote control to start detection, then the health check signal will flash . After entering the health check state, please keep your body relaxed. Gently place your index or middle finger on the sensor and the detect will start after several seconds. After the detection is completed, the health check signal is always on . Blood oxygen (1XXX refers to blood oxygen concentration), heart rate (0XXX stand for heart rate) and fatigue index (The whole test takes 40 to 60 seconds) will be displayed on the interface. There are four fatigue levels: "Good state," "Mild fatigue," "Moderate fatigue" and "Severe fatigue." If you do not press the health check button within 10 seconds, automatic program will be recommended for you automatically according to your fatigue level. If you press the health check button within 10 seconds, it will be returned to the previous massage program. During the detecting process, you can also press the health check button to return to previous massage program. If the detection is not successful for more than 120 seconds, the detection is exited and returns to the previous massage state.

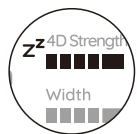

Fatigue Level			
Good state 	Mild fatigue 	Moderate fatigue 	Severe fatigue

Operation Instructions

VI. Massage adjustment (please use this function after the chair is turned on)

1. 4D intensity adjustment: 4D intensity can be adjusted by pressing the 4D intensity button on remote control or shortcut buttons on armrest.

- (1) There are five levels from Level 1 to Level 5. Level 1 represents the minimum intensity and Level 5 the maximum. The stronger the 4D intensity, the higher the massage roller is lifted and the greater the massage intensity.

(2) 4D intensity displayed on the LCD interface

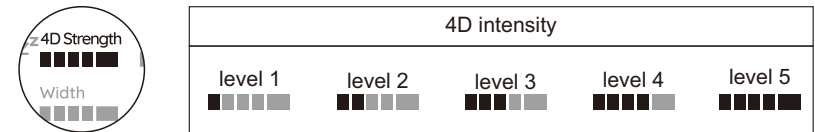

2. Time adjustment: massage time can be adjusted by timer button on remote control, the adjustment range is 0–40 minutes.

3. Pressing the shoulder position button by remote control to finely adjust the shoulder positions upwards or downwards. If you feel the positions are inaccurate when massaging, you can adjust the shoulder positions.

VII. Angle adjustment (please use this function after the chair is turned on)

1. Zero-gravity





Function	Description
ZERO	There are two levels corresponding to the two set angles of the massage chair. You can press the Zero-gravity key to switch repeatedly between the three zero-gravity levels or turn off the zero-gravity.

2. Whole body angle

Function	Description
	Press and hold the Seat-down key on the remote control to start adjusting the angle of the massage chair downwards, where the backrest mechanism is lowered and the leg mechanism is raised, the adjustment will stop when the key is released. When the adjustment reaches the limit position, the adjustment will stop and beeps will be emitted.
	Press and hold the Seat-up key on the remote control to start adjusting the angle of the massage chair upwards, where the backrest mechanism is raised and the leg mechanism lowered and release the key to stop the adjustment. When the adjustment reaches the limit position, the adjustment will stop and beeps will be emitted.

Operation Instructions

3. Leg mechanism angle

Function	Description
	Press and hold the Calf-down key  on the remote control to start adjusting the angle of the leg mechanism downwards, release the key to stop the adjustment. When the adjustment reaches the limit position, the adjustment will stop and beeps will be emitted.
	Press and hold the Calf-up key  on the remote control to start adjusting the angle of the leg mechanism upwards, release the key to stop the adjustment. When the adjustment reaches the limit position, the adjustment will stop and beeps will be emitted.

VIII. Double massage hand operation

1. Automatic mode

In automatic mode, the upper and lower massage hand will operate automatically according to the current program and cannot be adjusted manually.

2. Manual mode

In manual mode, Press and hold the manipulation button to switch between upper and lower massage hand control. Manual Icon^{Manual} is always on for upper hand control, and the manual Icon^{Manual} is flashing for lower massage hand control. The lower hand control can use the three buttons of maneuver, up and down adjustment, and 4d intensity.

IX. Voice control (please use this function after the chair is turned on)

Press and hold voice control button  on remote control or armrest to turn on or off voice assistant function. After opening the voice assistant you can use the voice assistant function to control the massage chair. Use method as follows:

(1) You can say "Hi Alice" or "Hey Alice" near the speaker or press the Voice key  on the right armrest to wake up the voice assistant. When replying "I am here", the voice assistant has been awakened.

(2) After waking up the voice assistant, please say your command within 6 seconds to control functions of the massage chair. After the voice assistant responds to your command, you can continue to say another command. Be sure to keep an interval of no more than 6 seconds between every two adjacent commands. Otherwise, you need to wake up the voice assistant again. The detailed voice command table is as follows:



Operation Instructions

Voice Control Entry		
Entry: "Hi Alice" or "Hey Alice". Answer: I am here.		
No.	Voice control entry	Answer entry
1	Massage on	Answer: Ok, Massage on
2	Massage close	Answer: Ok, Massage close
3	Total Relax	Answer: Ok, Total Relax
4	Energy Boost	Answer: Ok, Energy Boost
5	Sweet Dream	Answer: Ok, Sweet Dream
6	Neck & Shoulder Care	Answer: Ok, Neck & Shoulder Care
7	Lunch Break	Answer: Ok, Lunch Break
8	Thai Massage	Answer: Ok, Thai Massage
9	Open the air pressure	Answer: Ok, Open the air pressure
10	Close the air pressure	Answer: Ok, Close the air pressure
11	Up the seat position	Answer: Ok, Up the seat position
12	Down the seat position	Answer: Ok, Down the seat position
13	Change the other mode	Answer: Ok, Change the other mode
14	Go little down	Answer: Ok, Go little down
15	Go little up	Answer: Ok, Go little up

Note: commands 14 and 15 can only be used after command 13.

Operation Instructions

X. Massage close

1. During the massage, you can press the Power key  on the remote control or the Power key  on the right armrest to turn off the chair. Immediately turn off all massage functions, re-set the massage roller, and massage chair angle reset to the highest sitting position.
2. During the massage, massage time countdown will also end the massage, immediately turn off massage chair and all massage function, re-set the massage roller, and massage chair angle remains the same.
3. Cut off the whole power, as shown in the attached figure (Schematic diagram of power switch position of the whole machine).

Cut off the whole machine power supply, as shown in the figure (Schematic diagram of power switch position of the whole machine).

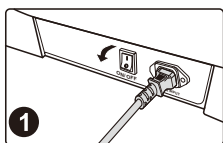

Turn off the power switch ("0" position)

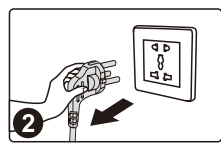

Schematic diagram of pulling out the power plug

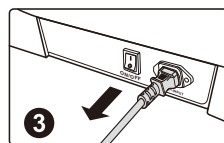

Remove the product connection power cord

Cleaning and Maintenance

Cleaning synthetic leather and plastic parts

Wipe the leather with a soft, dry cloth.

- Do not use chemicals such as thinner, gasoline, alcohol, etc. to clean the unit.
- When using commercially available leather care products (rags), please follow the instructions for use.
- If synthetic leather is particularly dirty, wipe it in the following way.

- ① Immerse a soft cloth in water or hot water containing 3% to 5% neutral detergent, then wring it out thoroughly.
- ② Use the above soft cloth to wipe the leather surface.
- ③ Wipe off the cleaning solution with a cloth soaked in clean water and thoroughly wrung out.
- ④ Wipe with a wrung soft cloth.
- ⑤ Let it air dry naturally.

- When it is difficult to remove stains, please immerse commercially available melamine foam in neutral detergent, and then wipe the machine with it.
- Do not use a hair dryer to dry the surface.
- Be careful when wiping the machine with denim and colored fabrics, as the color of the fabric will stain the surface of the synthetic leather.
- Do not keep these parts in contact with plastic for a long time, as this will cause discoloration.
- Synthetic leather may be discolored, so when using hair dye, please cover the touched part with a towel.



Troubleshooting

Fault	When the calf mechanism or the backrest reaches a certain position, press the corresponding adjustment button and it will no longer change, and a continuous "beep, beep" sound will be emitted.
Solution	Due to product structure design and ergonomic requirements, this product has a limited protection design for the limit state of attitude adjustment. At the same time, a reminder sound will sound when the limit is reached.
Fault	The function does not work or some functions do not work after the machine is turned on.
Solution	After the machine is turned on by pressing the switch key, it is necessary to manually select an automatic massage program or other working state. If it is not operated, the machine will automatically shut down after 20 minutes. If the manual operation mode is selected, the functions that are not selected may be disabled, and the working mode needs to be manually set in the manual mode.
Fault	The machine makes a leather rubbing sound when adjusting its posture.
Solution	This product adopts high-grade anti-corrosion leather that meets environmental protection requirements. Due to the inherent characteristics of leather materials, there will be a normal slight noise when rubbing at the relative movement, which is a normal phenomenon. Note: If you hear fabric or leather tearing sound when the machine is running, please stop using it immediately and seek professional maintenance.
Fault	The massage wheel did not reach the shoulders or neck.
Solution	If the head does not touch the head cushion or the back does not touch the backrest, the shoulder position may be lower than the actual position during the body shape detection process. Sit in the deepest position of the seat, rest your head on the headrest, and start over from the beginning.
Fault	The unit is damaged. The power cord or power plug is abnormally hot.
Solution	To prevent accidents, be sure to contact an authorized service center.

Please feel free to contact the designated service personnel for any questions or doubts about this product.

Product specifications

Model: SL-A520 PREMIER DUAL 4D+2D

Name: Massage Chair

Rated voltage: 110-120V~ 60Hz
220-240V~ 50Hz/60Hz

Rated power: 150W

Rated time: 20min

Safety structure: Class I

Material description: PVC, PA, steel parts, electric and electron components

MATERIAL	PU	LEATHER	CLOTH	WOOD

